

3ST\_ladder assembly\_2 in.dwg

16.04.2024

Roman

NOTES:

- 1. ALL UNITS ARE IN INCHES
- 2. MATERIAL AL 6063-T5
- 3. SEE INDIVIDUAL PART DRAWINGS FOR ADD'L DIMS

INTERNATIONAL DOCK PRODUCTS, INC.  
 Pembroke Park, FL  
[DOCKPRODUCTS.COM](http://DOCKPRODUCTS.COM)

| REVISIONS |     |                            |           |          |
|-----------|-----|----------------------------|-----------|----------|
| ZONE      | REV | DESCRIPTION                | DATE      | APPROVED |
| NA        | A   | NEW RELEASE                | 6/15/2023 | RK       |
| NA        | B   | ADDED TOP VIEW DIM - 14.32 | 4/12/2024 | RK       |

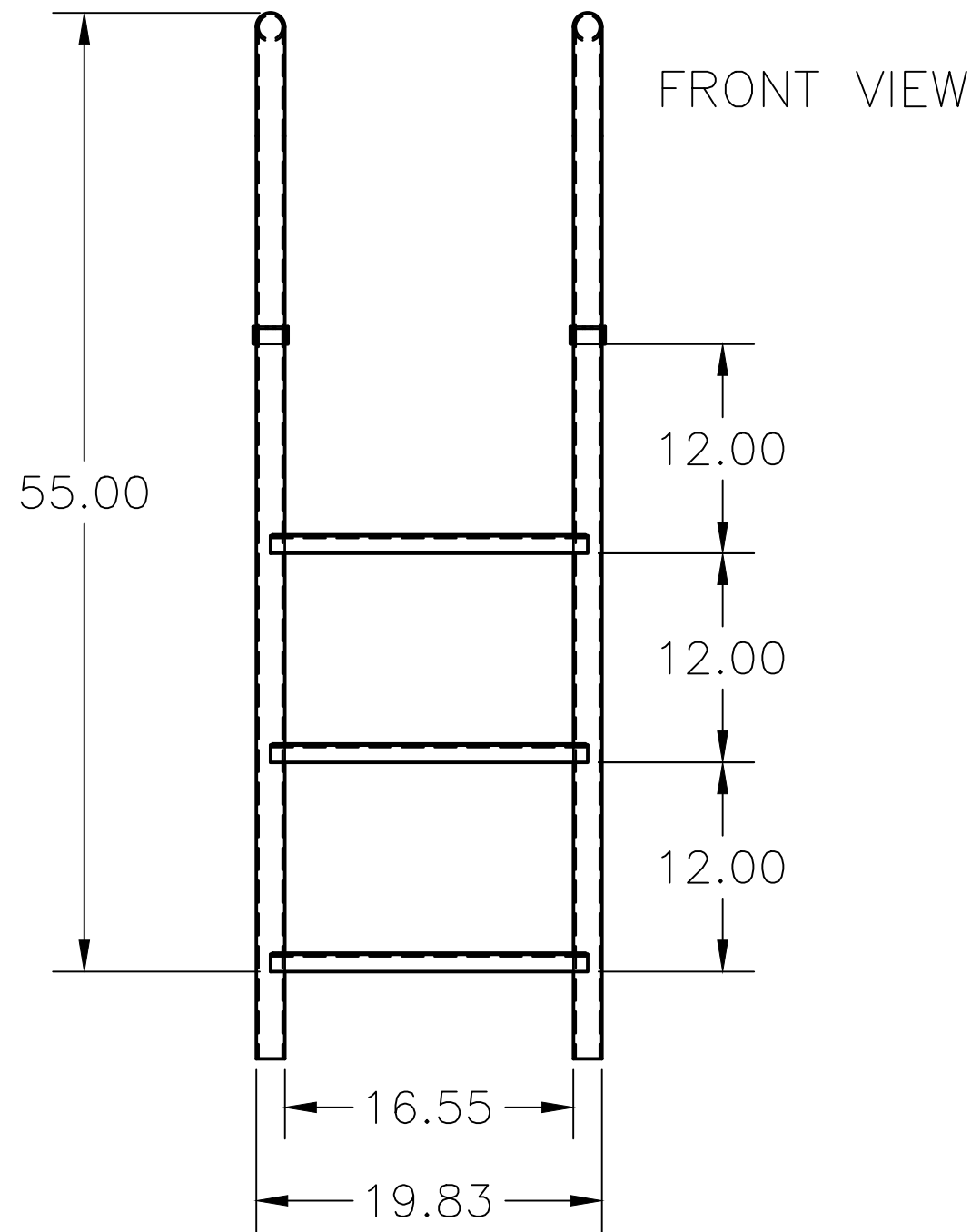

SIDE VIEW

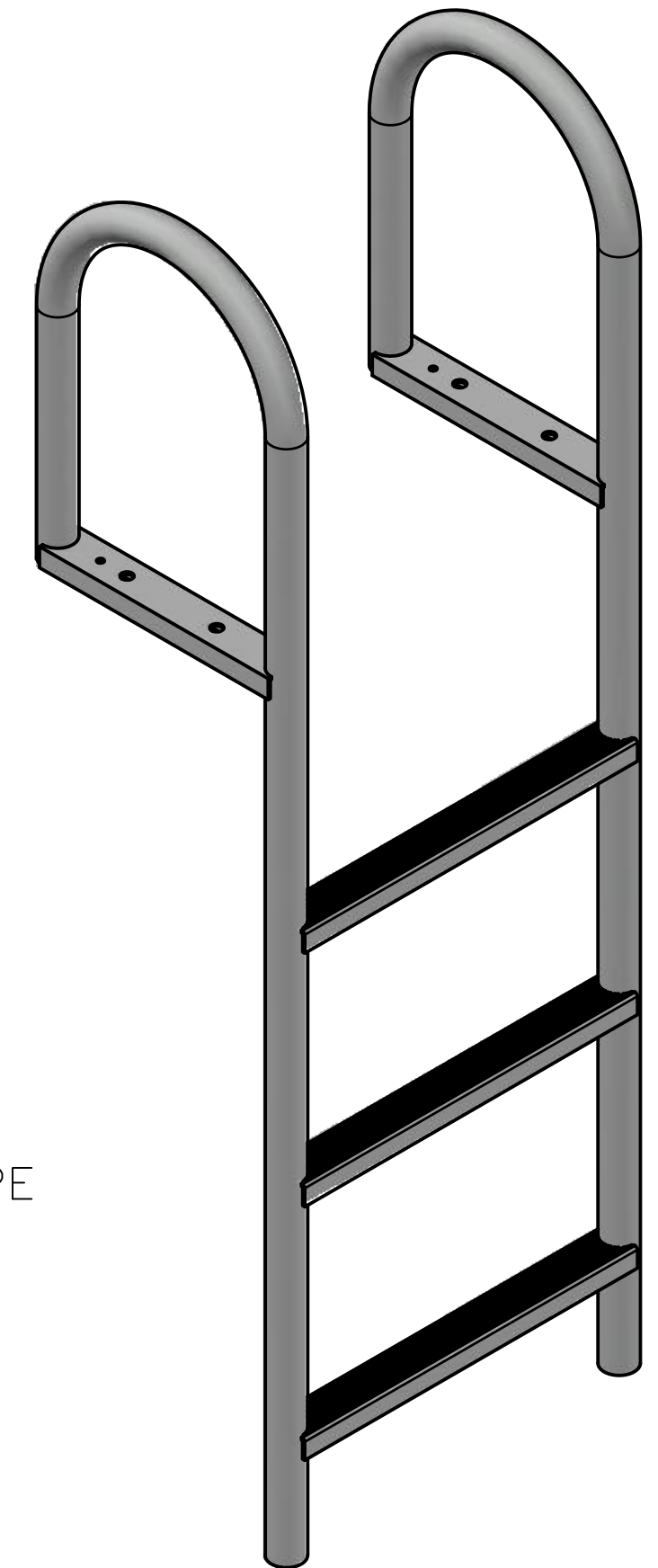
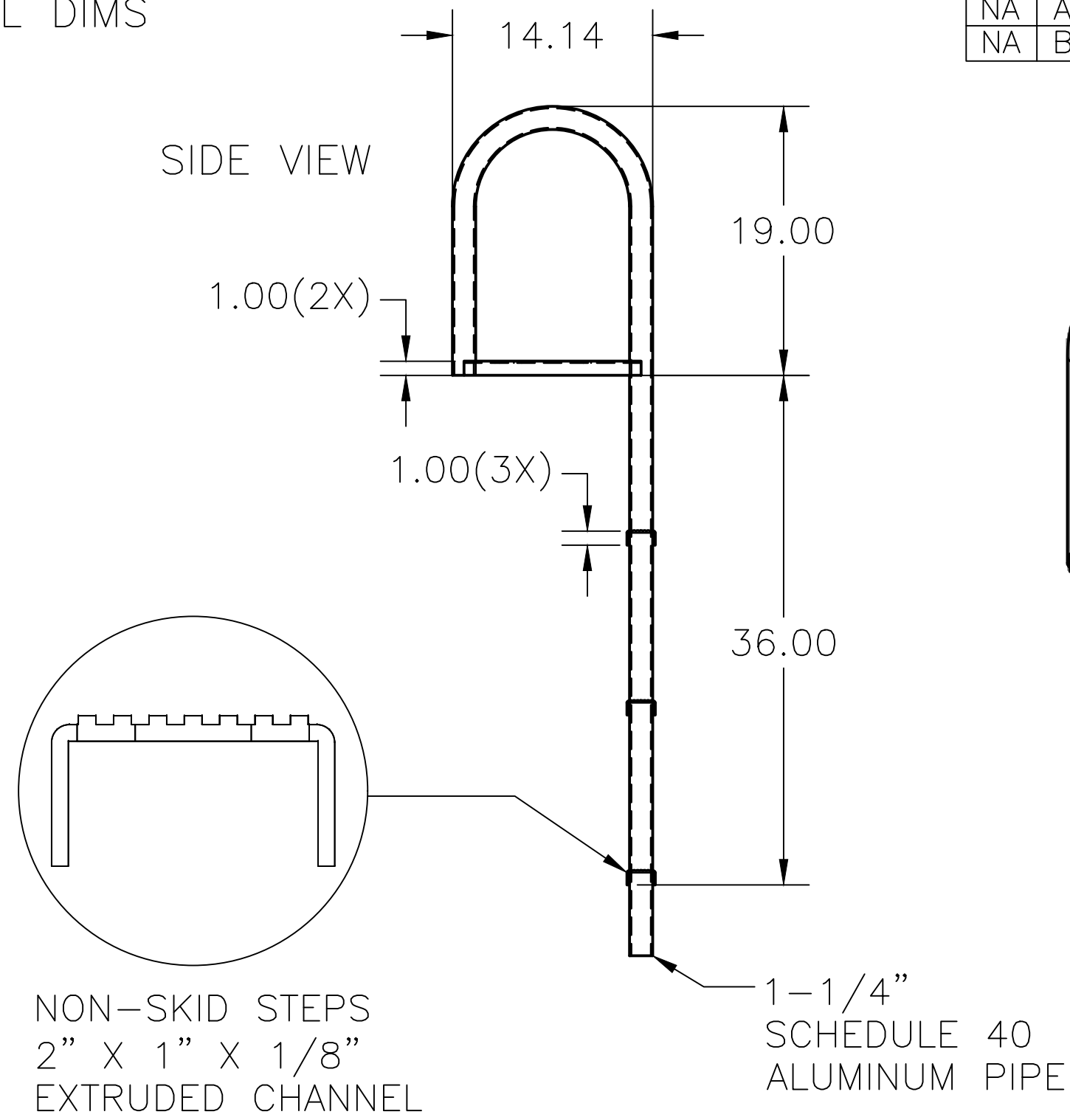

WATER SIDE

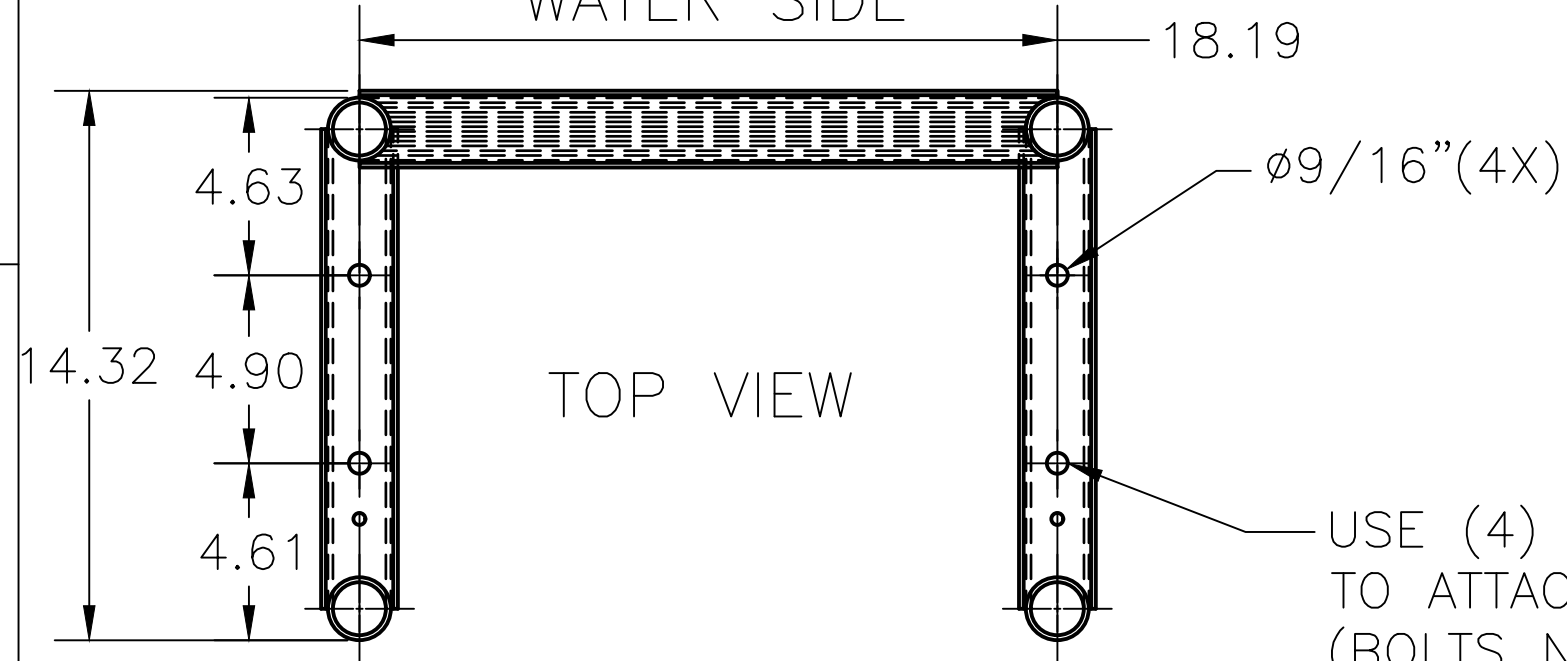

|  |         |                     |           |  |
|--|---------|---------------------|-----------|--|
| FILE NAME 3ST_ladder assembly_2 in.dwg |         |                     |           |  |
| CONTRACT NO NA                         |         |                     |           |  |
| DRAWN 6/22/2023                        |         |                     |           |  |
| CHECK                                  |         |                     |           |  |
| APPR.                                  |         |                     |           |  |
| ISSUED                                 |         |                     |           |  |
| SIZE                                   | FSCM NO | DWG NO              | REV       |  |
| C                                      | NA      | 3ST_ASSY_2_in - 001 | B         |  |
| SCALE 1:1.001                          |         | WEIGHT              | SHEET 1/1 |  |

DRAWING-LADDER-STRAIGHT-3

3ST\_ladder assembly\_4 in.dwg

16.04.2024

Roman

NOTES:

- 1. ALL UNITS ARE IN INCHES
- 2. MATERIAL AL 6063-T5
- 3. SEE INDIVIDUAL PART DRAWINGS FOR ADD'L DIMS

INTERNATIONAL DOCK PRODUCTS, INC.  
 Pembroke Park, FL  
[DOCKPRODUCTS.COM](http://DOCKPRODUCTS.COM)

| REVISIONS |     |                            |           |          |
|-----------|-----|----------------------------|-----------|----------|
| ZONE      | REV | DESCRIPTION                | DATE      | APPROVED |
| NA        | A   | NEW RELEASE                | 6/21/2023 | RK       |
| NA        | B   | ADDED TOP VIEW DIM - 16.12 | 4/12/2024 | RK       |

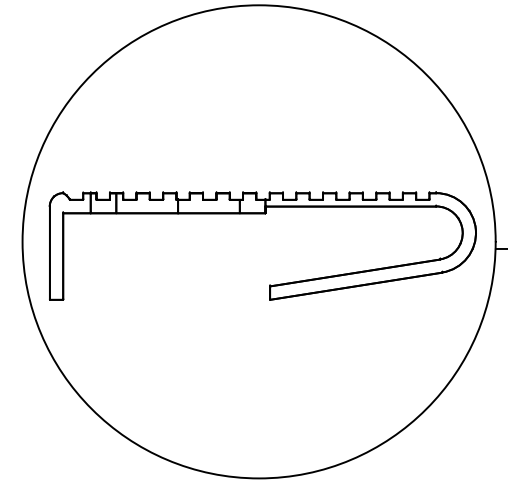
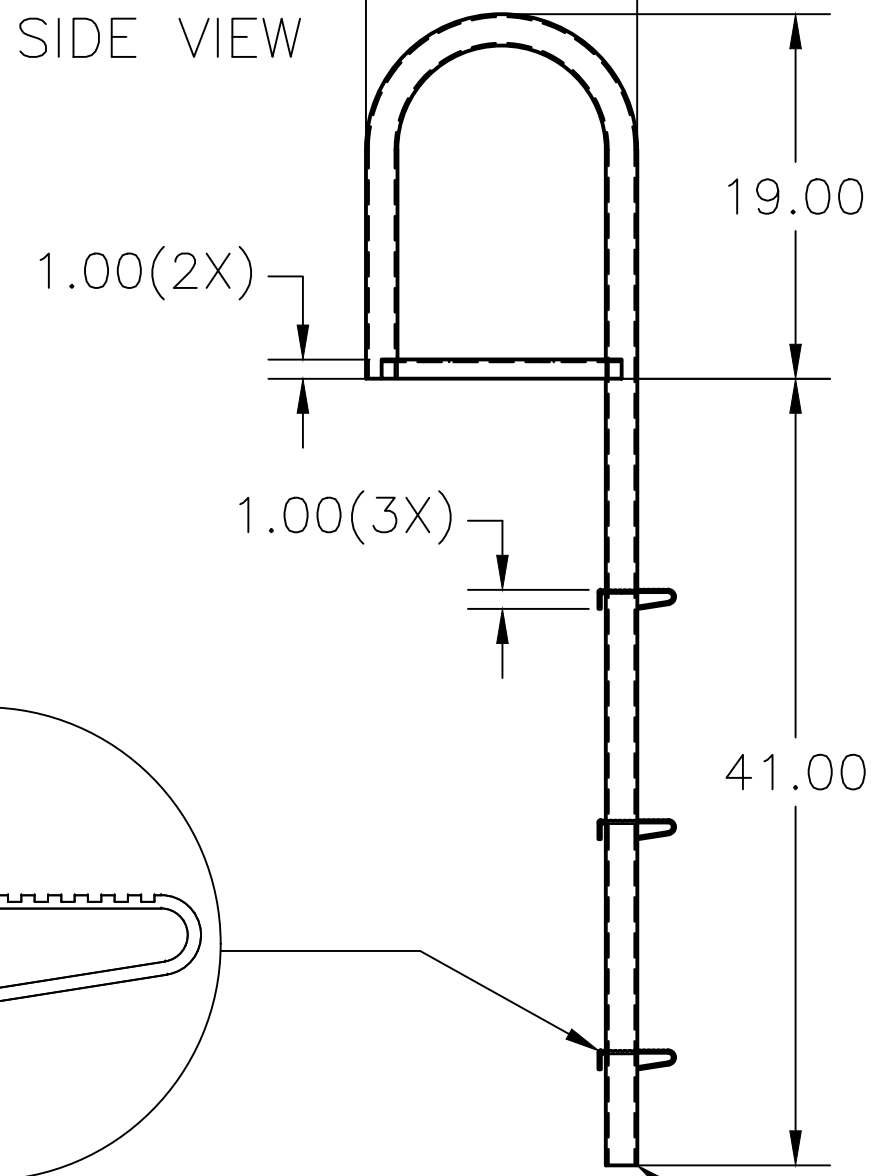
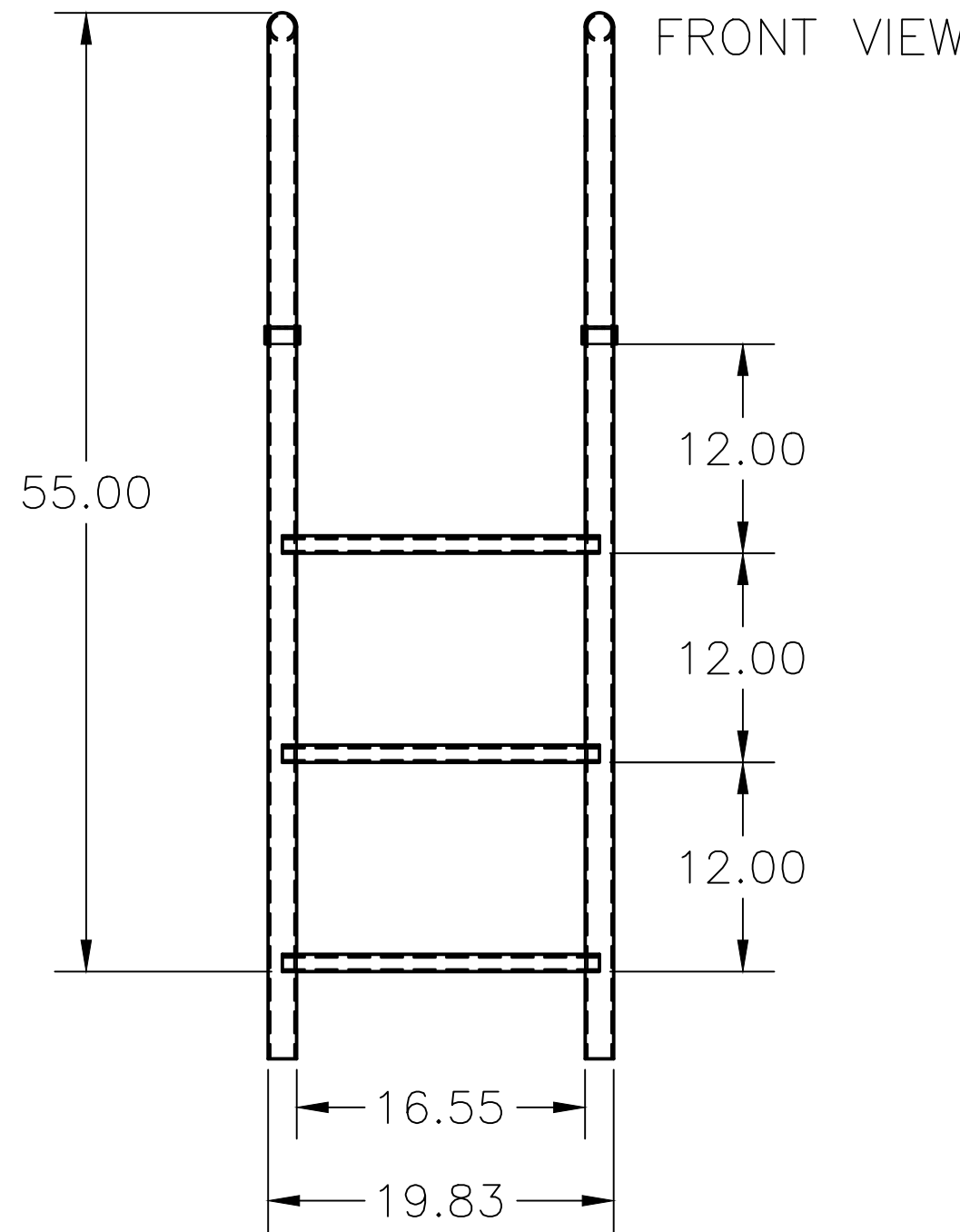

1-1/4"  
SCHEDULE 40  
ALUMINUM PIPE

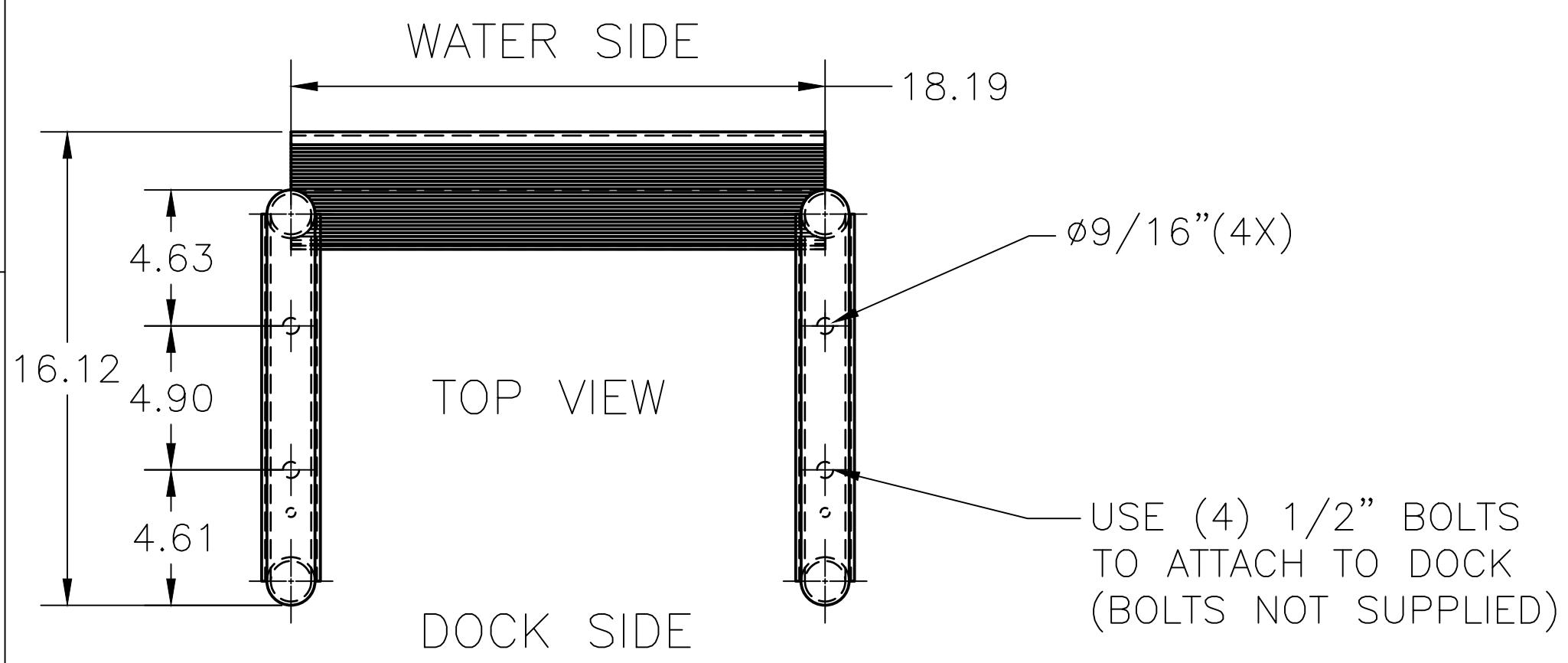
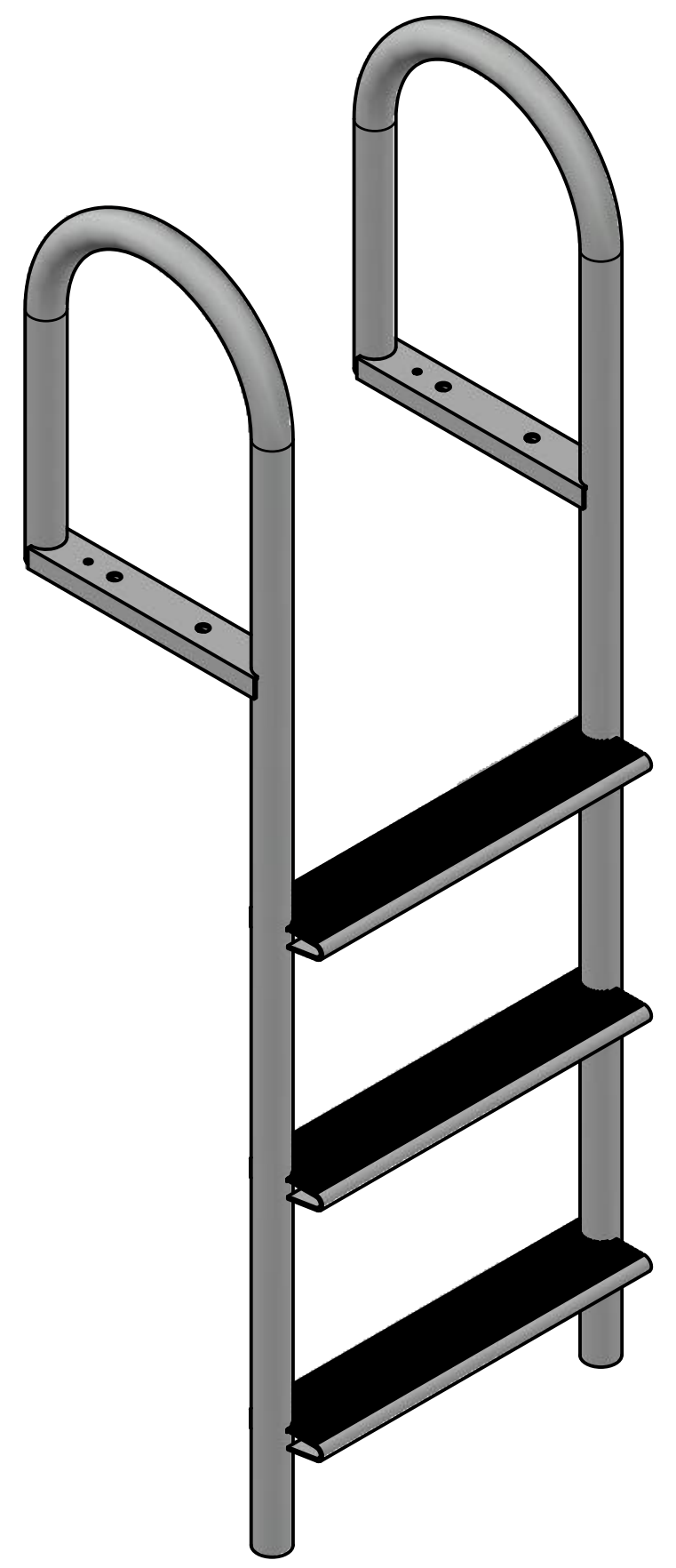

|  |         |                     |           |  |
|--|---------|---------------------|-----------|--|
| FILE NAME 3ST_ladder assembly_4 in.dwg |         |                     |           |  |
| CONTRACT NO NA                         |         |                     |           |  |
| DRAWN 6/22/2023                        |         |                     |           |  |
| CHECK                                  |         |                     |           |  |
| APPR.                                  |         |                     |           |  |
| ISSUED                                 |         |                     |           |  |
| SIZE                                   | FSCM NO | DWG NO              | REV       |  |
| C                                      | NA      | 3ST_ASSY_4_in - 001 | B         |  |
| SCALE 1:1.001                          |         | WEIGHT              | SHEET 1/1 |  |