

4ST_ladder_assembly_2 in.dwg

16.04.2024

Roman

NOTES:

- 1. ALL UNITS ARE IN INCHES
- 2. MATERIAL AL 6063-T5
- 3. SEE INDIVIDUAL PART DRAWINGS FOR ADD'L DIMS

INTERNATIONAL DOCK PRODUCTS, INC.
 Pembroke Park, FL
DOCKPRODUCTS.COM

| REVISIONS | | | | |
|-----------|-----|----------------------------|-----------|----------|
| ZONE | REV | DESCRIPTION | DATE | APPROVED |
| NA | A | NEW RELEASE | 6/26/2023 | RK |
| NA | B | ADDED TOP VIEW DIM - 14.32 | 4/12/2024 | RK |

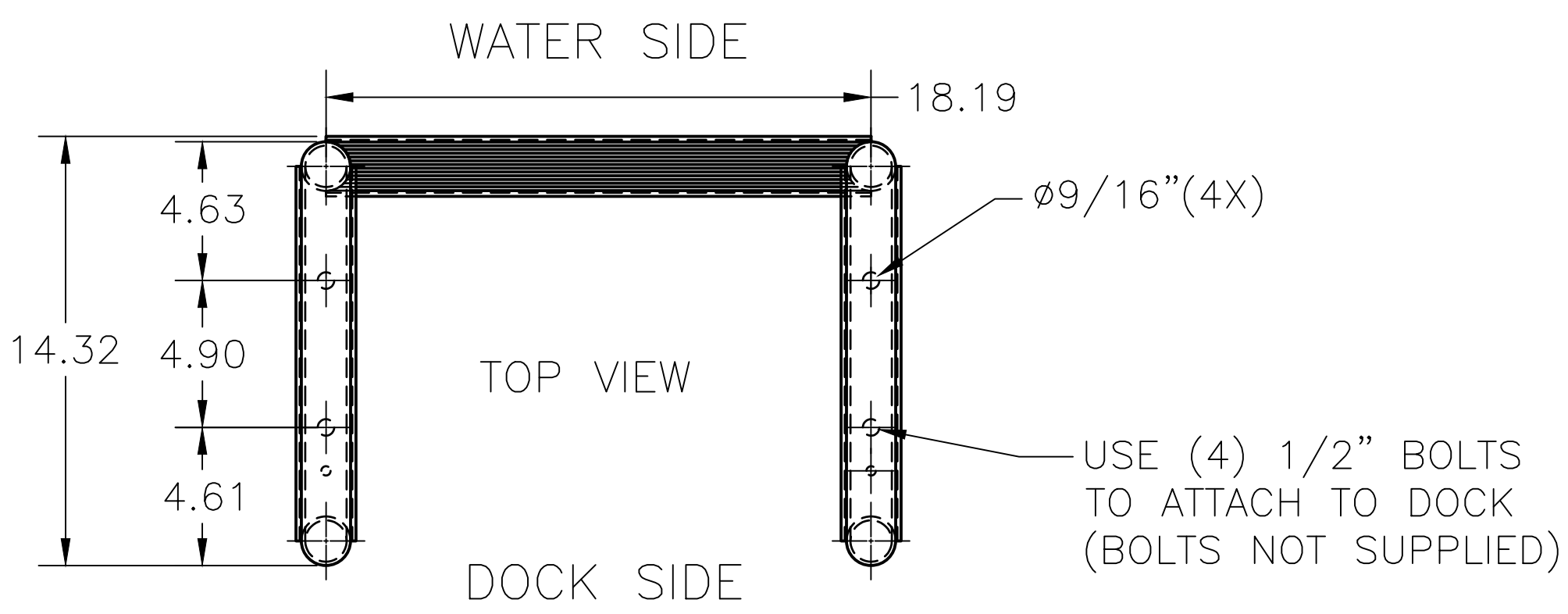
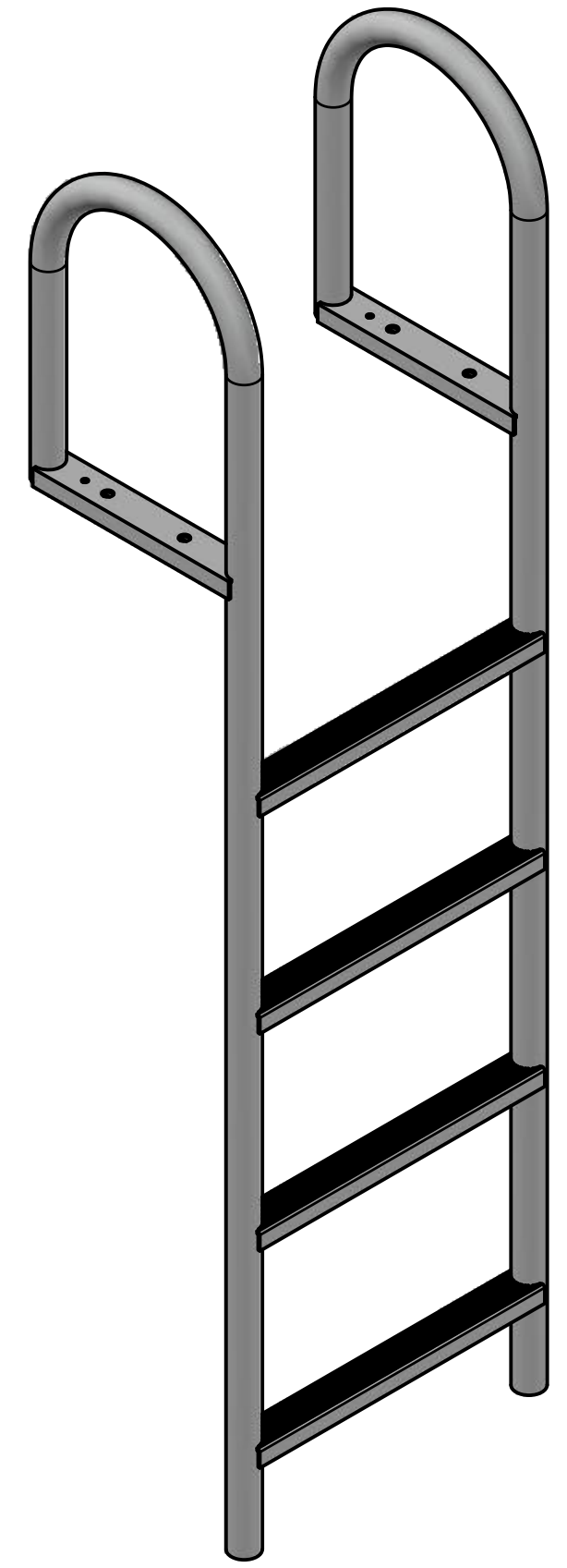
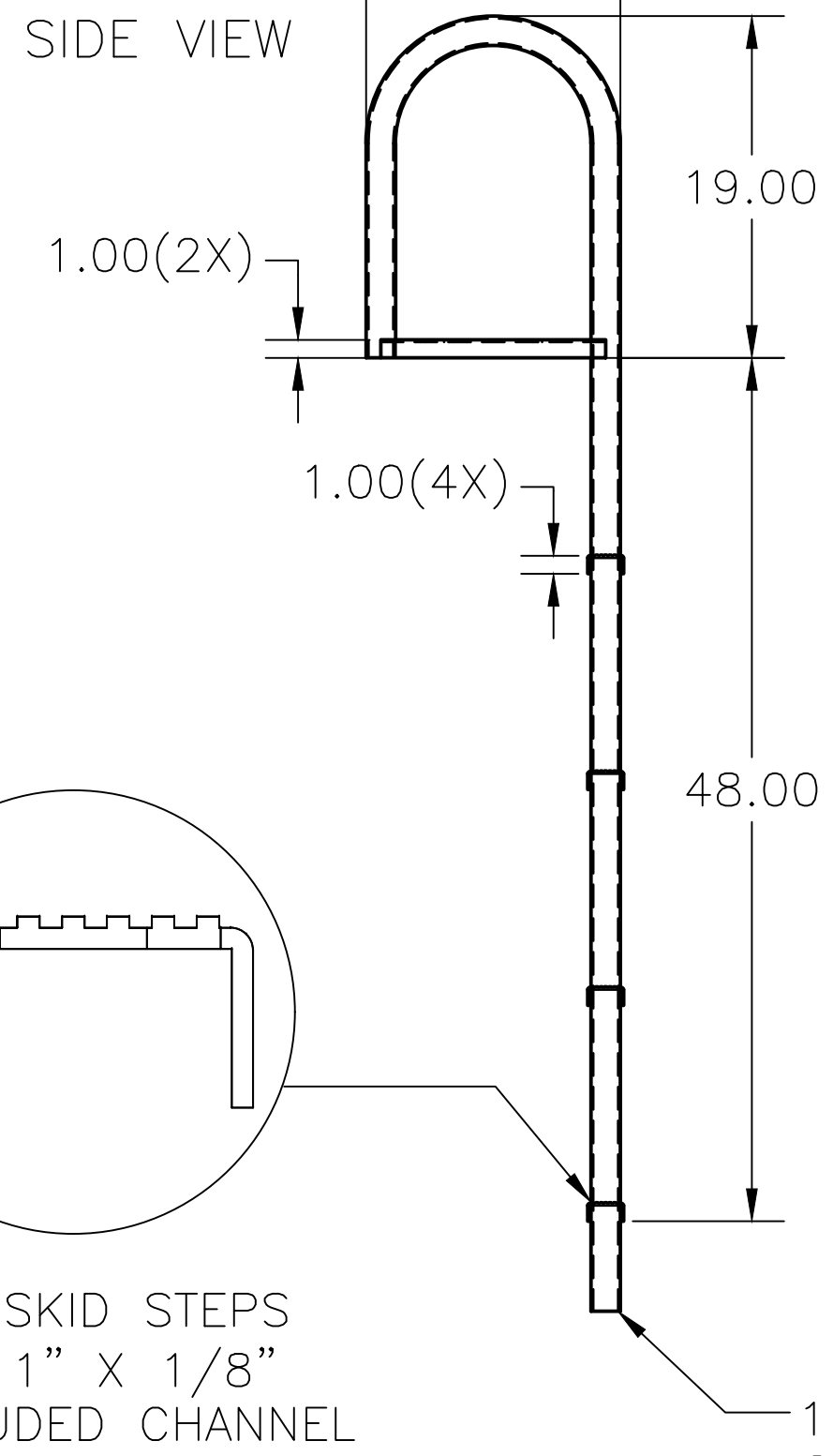
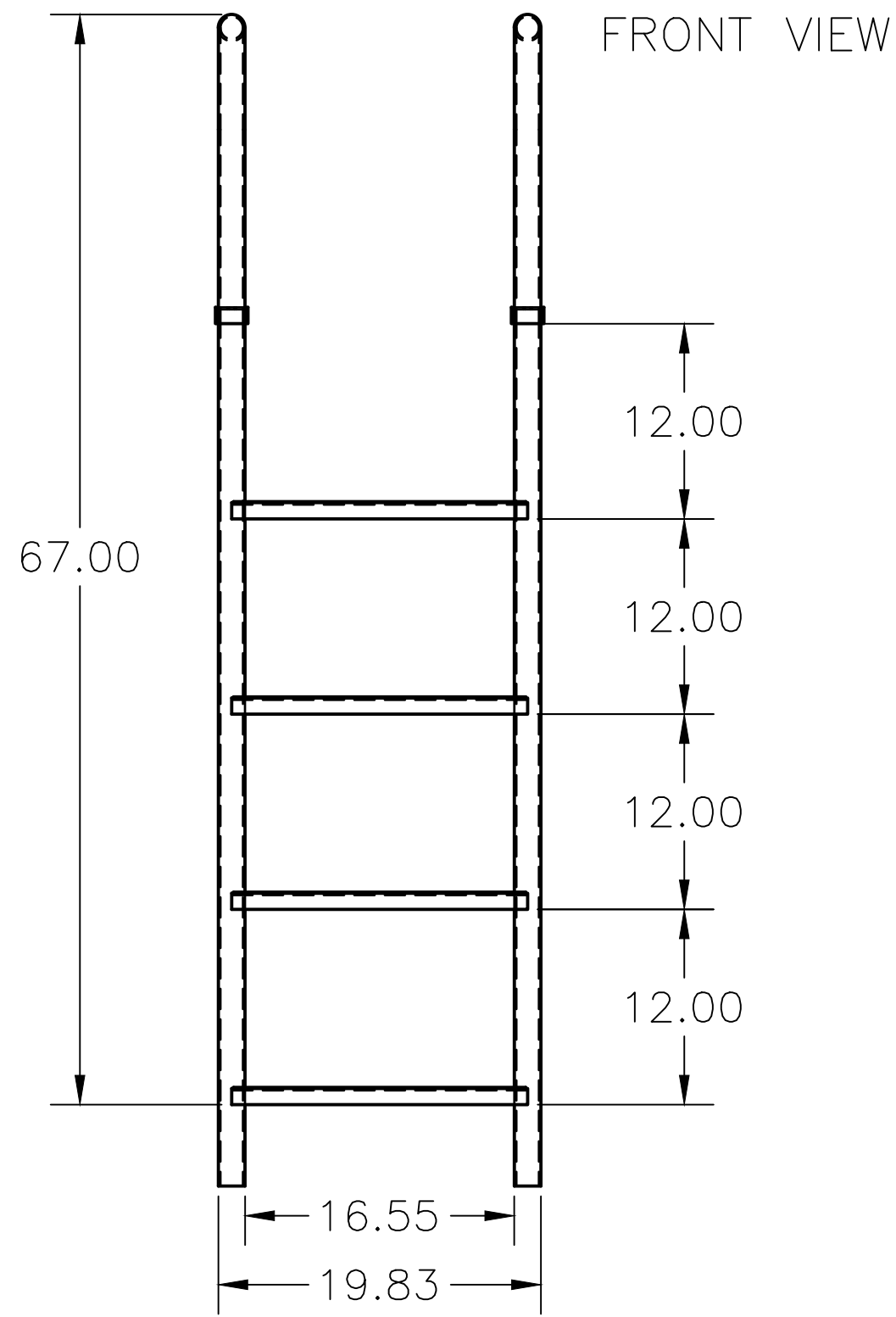

| | | | |
|--|---------|---------------------|-----------|
| FILE NAME 4ST_ladder_assembly_2 in.dwg | | | |
| CONTRACT NO NA | | | |
| DRAWN 6/23/2023 | | | |
| CHECK | | | |
| APPR. | | | |
| ISSUED | | | |
| SIZE | FSCM NO | DWG NO | REV |
| C | NA | 4ST_ASSY_2_in - 001 | B |
| SCALE 1:1.001 | | WEIGHT | SHEET 1/1 |

LADDER-STRAIGHT-4

4ST_ladder assembly_4 in.dwg

16.04.2024

Roman

NOTES:

- 1. ALL UNITS ARE IN INCHES
- 2. MATERIAL AL 6063-T5
- 3. SEE INDIVIDUAL PART DRAWINGS FOR ADD'L DIMS

INTERNATIONAL DOCK PRODUCTS, INC.
 Pembroke Park, FL
DOCKPRODUCTS.COM

| REVISIONS | | | | |
|-----------|-----|----------------------------|-----------|----------|
| ZONE | REV | DESCRIPTION | DATE | APPROVED |
| NA | A | NEW RELEASE | 6/26/2023 | RK |
| NA | B | ADDED TOP VIEW DIM - 16.12 | 4/12/2024 | RK |

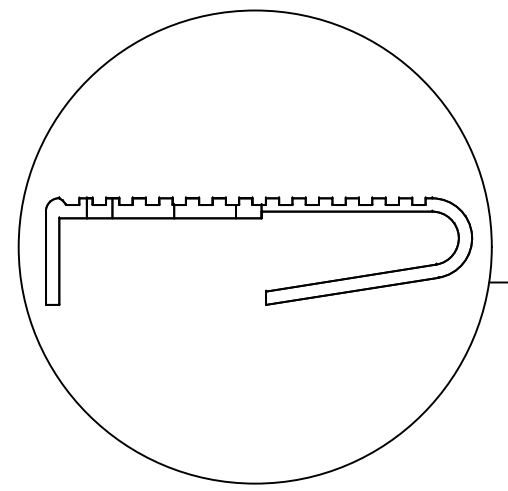
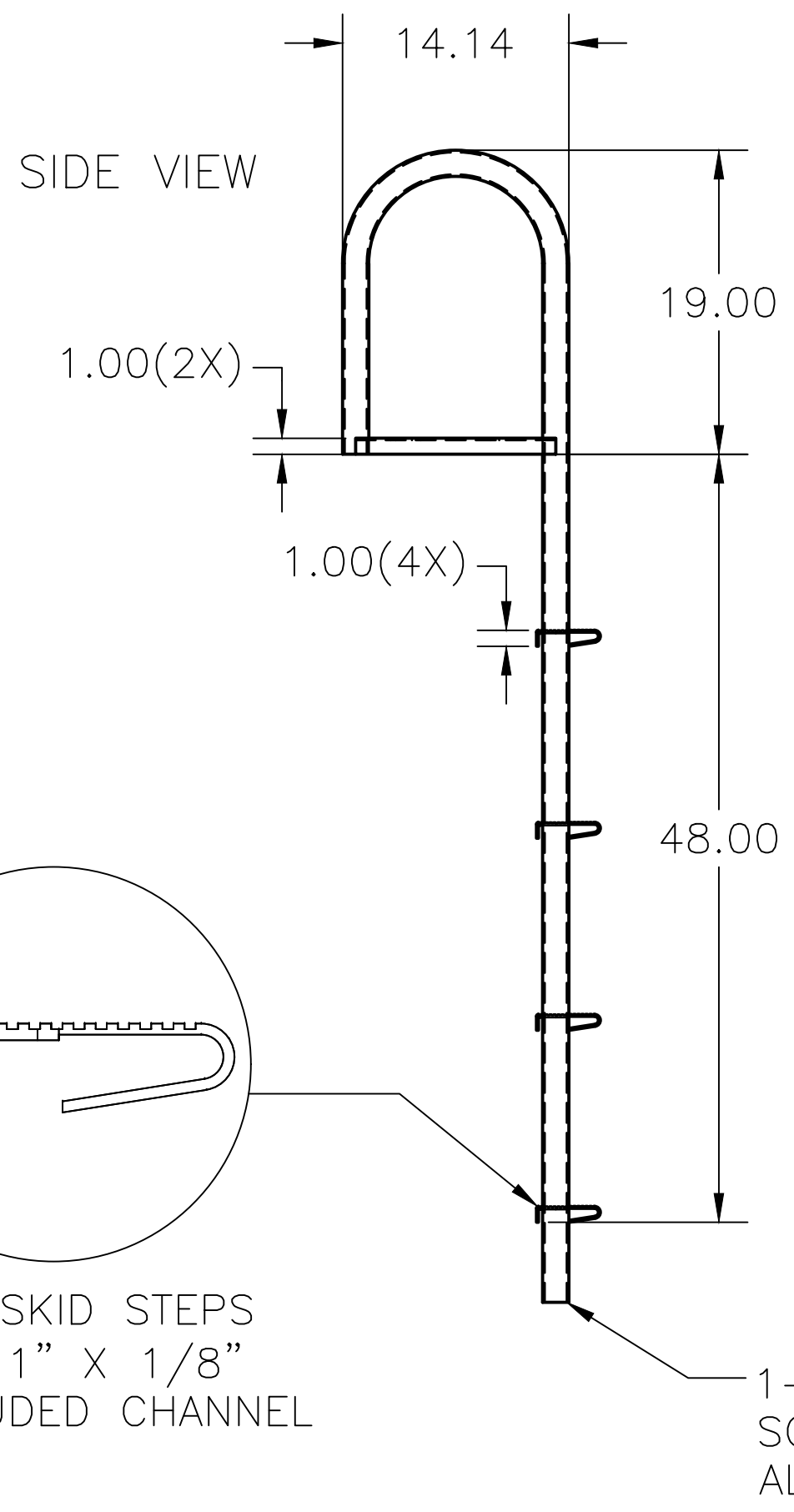
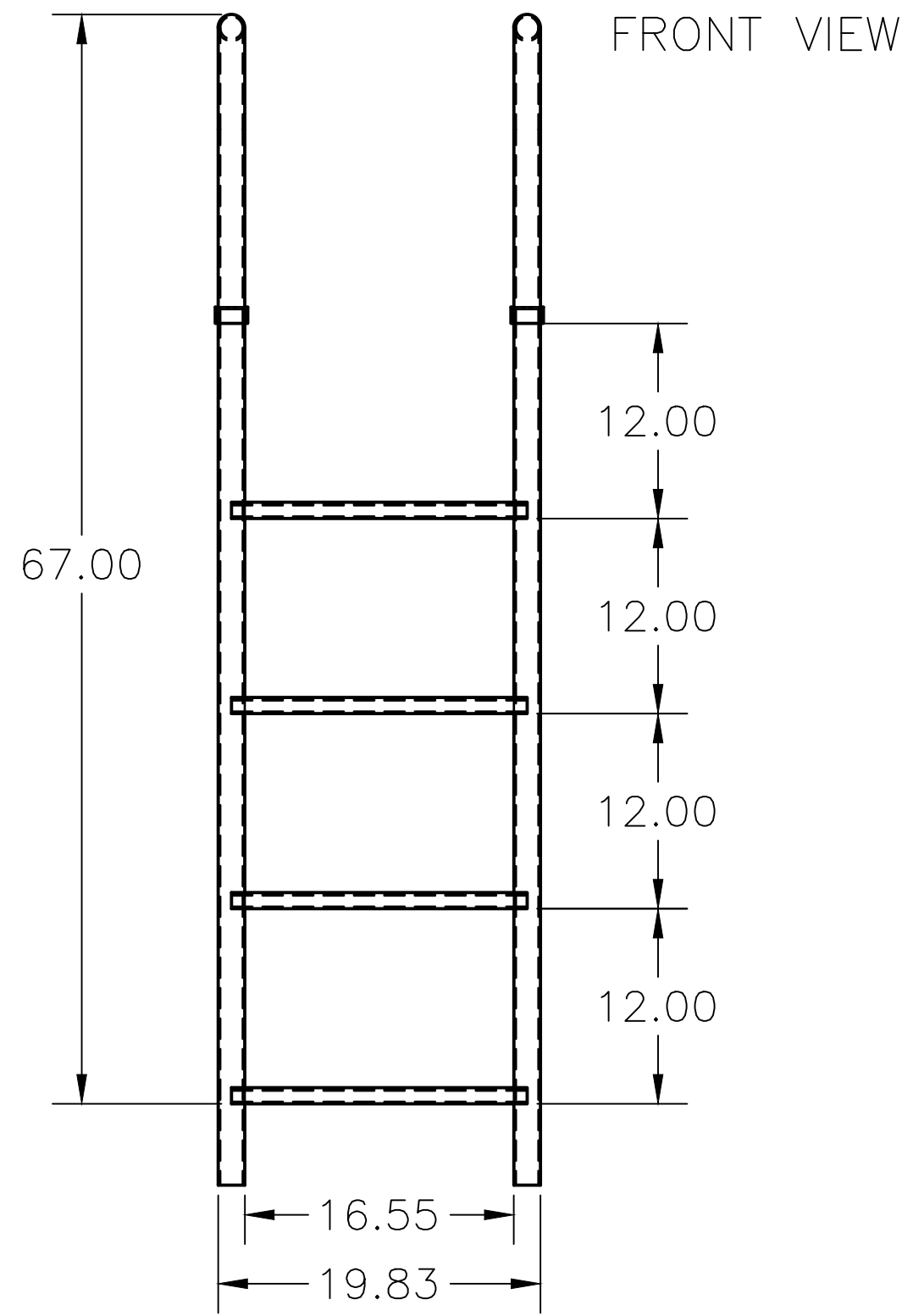

NON-SKID STEPS
 4" X 1" X 1/8"
 EXTRUDED CHANNEL

1-1/4"
 SCHEDULE 40
 ALUMINUM PIPE

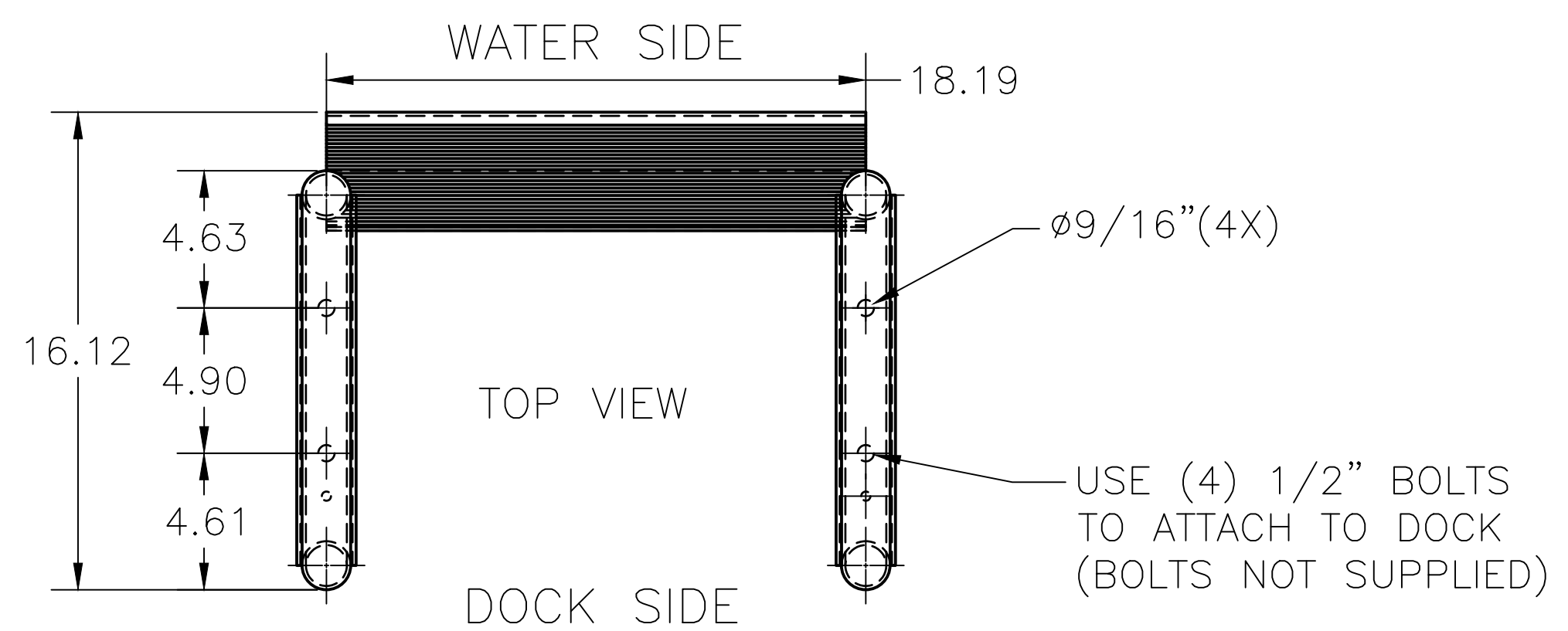
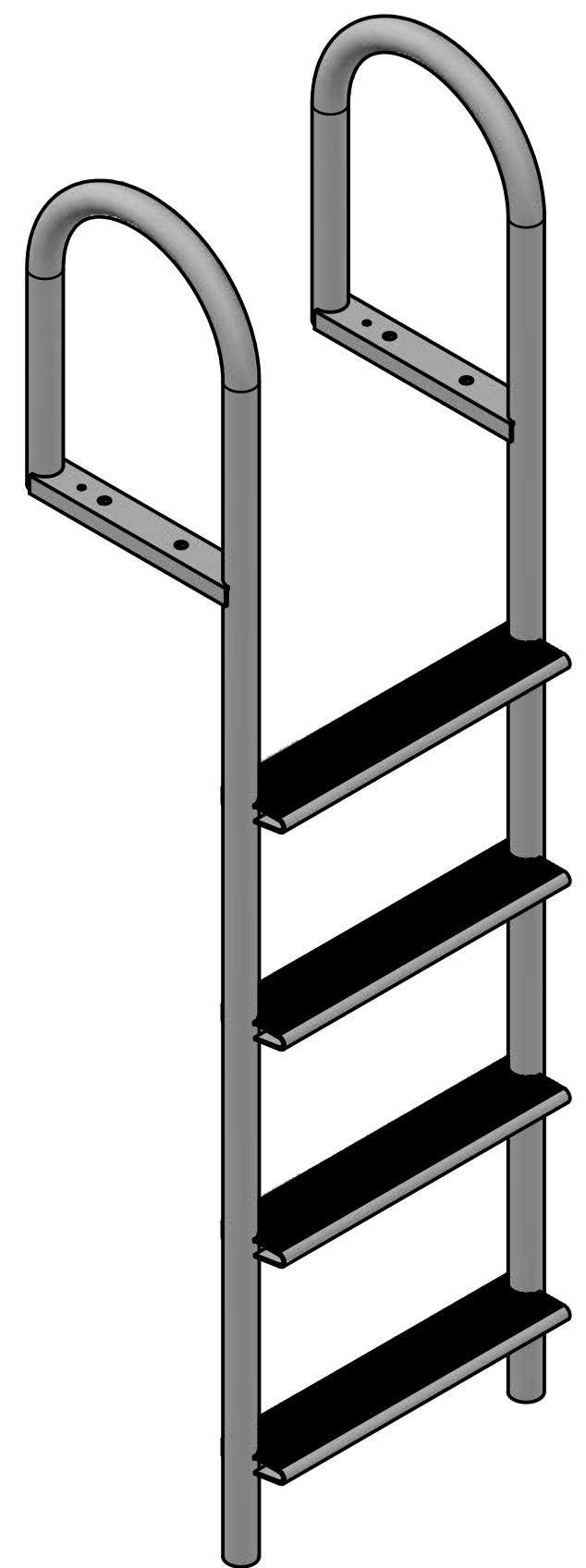

USE (4) 1/2" BOLTS
 TO ATTACH TO DOCK
 (BOLTS NOT SUPPLIED)

| | | | |
|--|---------|---------------------|-----------|
| FILE NAME 4ST_ladder assembly_4 in.dwg | | | |
| CONTRACT NO NA | | | |
| DRAWN 7/5/2023 | | | |
| CHECK | | | |
| APPR. | | | |
| ISSUED | | | |
| SIZE | FSCM NO | DWG NO | REV |
| C | NA | 4ST_ASSY_4_in - 001 | B |
| SCALE 1:1.001 | | WEIGHT | SHEET 1/1 |

LADDER-STRAIGHT-4-WIDE