

INTERNATIONAL DOCK PRODUCTS, INC.
 Pembroke Park, FL
DOCKPRODUCTS.COM

REVISIONS				
ZONE	REV	DESCRIPTION	DATE	APPROVED
NA	A	NEW RELEASE	6/24/2024	RK

SPC-36-2A

- (1) 30 AMP 125V TWISTLOCK
- (1) 20 AMP GFCI DUPLEX
- (1) HOSE FAUCET
- (1) HOSE HOLDER
- DIRECT FEED DISTRIBUTION BLOCK
- LED LIGHT & PHOTOCELL

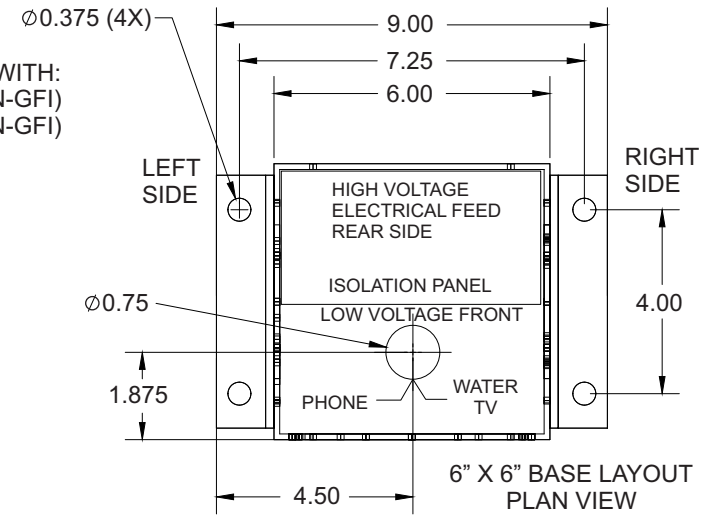
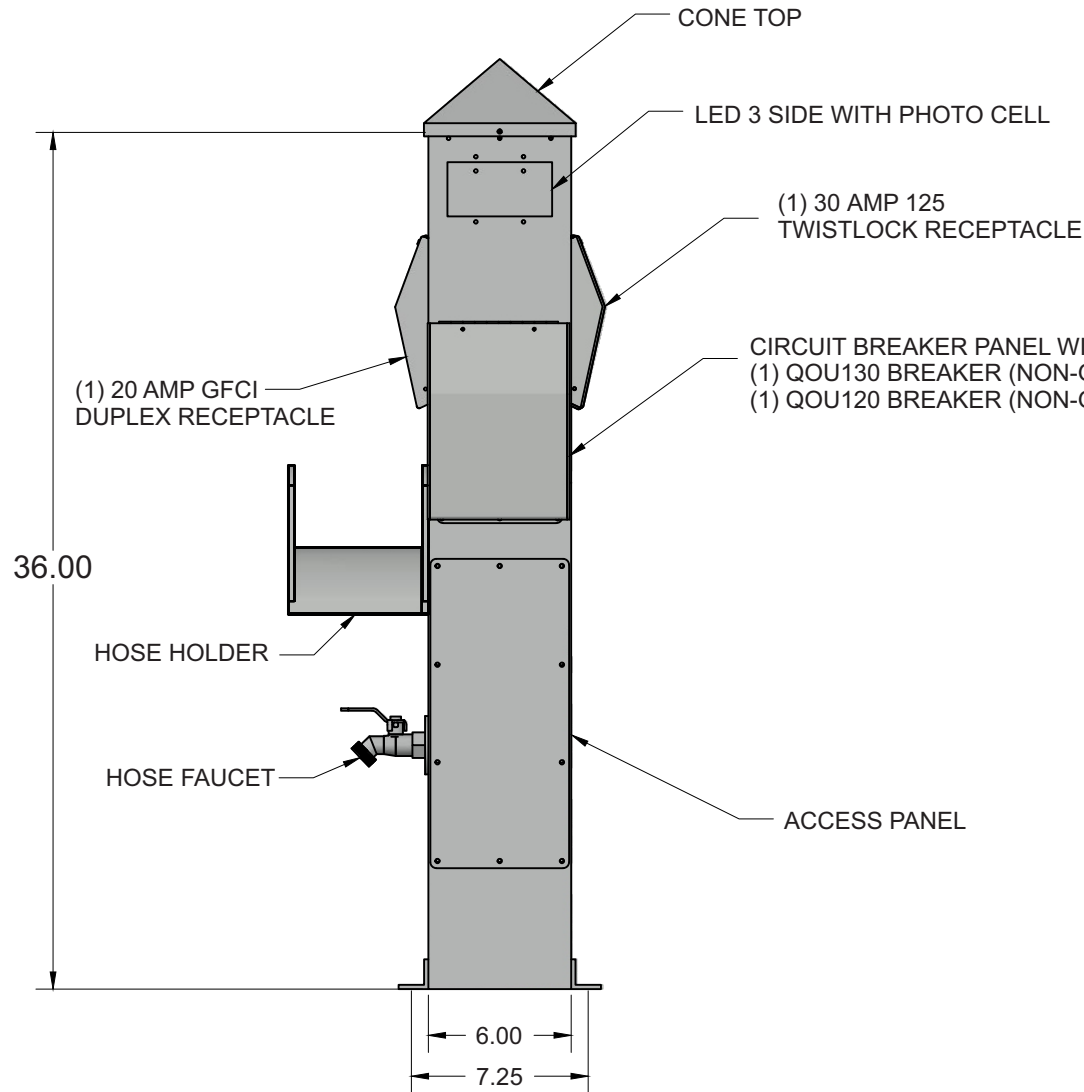

NOTES:

PEDESTAL FABRICATED FROM
 100% ALUMINUM CASING
 6 x 6 x 36 x 1/8 INCH
 POWDER COATED WHITE TO
 MARINE SPECIFICATIONS

Client shall accept any engineering drawing prepared by International Dock Products, Inc. prior to commencing manufacturing of product.

ACCEPTED

CLIENT NAME: _____ CLIENT SIGNATURE _____ DATE APPROVED: _____

CONTRACT NO NA		PEDESTAL-SPC-36-2A		
DRAWN 6/24/2024				
CHECK				
APPR.				
ISSUED				
SIZE	FSCM NO	DWG NO	SPC-36-2A	
SCALE 1:1.0008		WEIGHT	SHEET 1 OF 1	
			REV	A