

INTERNATIONAL DOCK PRODUCTS, INC.
 Pembroke Park, FL
 DOCKPRODUCTS.COM

REVISIONS				
ZONE	REV	DESCRIPTION	DATE	APPROVED
NA	A	NEW RELEASE	11/8/2024	RK

SPC-21-3T-XXX-XXX
 (1) 50 AMP 125/250V TWISTLOCK
 (1) 30 AMP 125V TWISTLOCK
 (1) 20 AMP GFCI DUPLEX
 LED LIGHT AND PHOTOCELL
 DIRECT FEED POWER DISTRIBUTION BLOCK
 MOUNTING BRACKETS FOR ROUND PILING

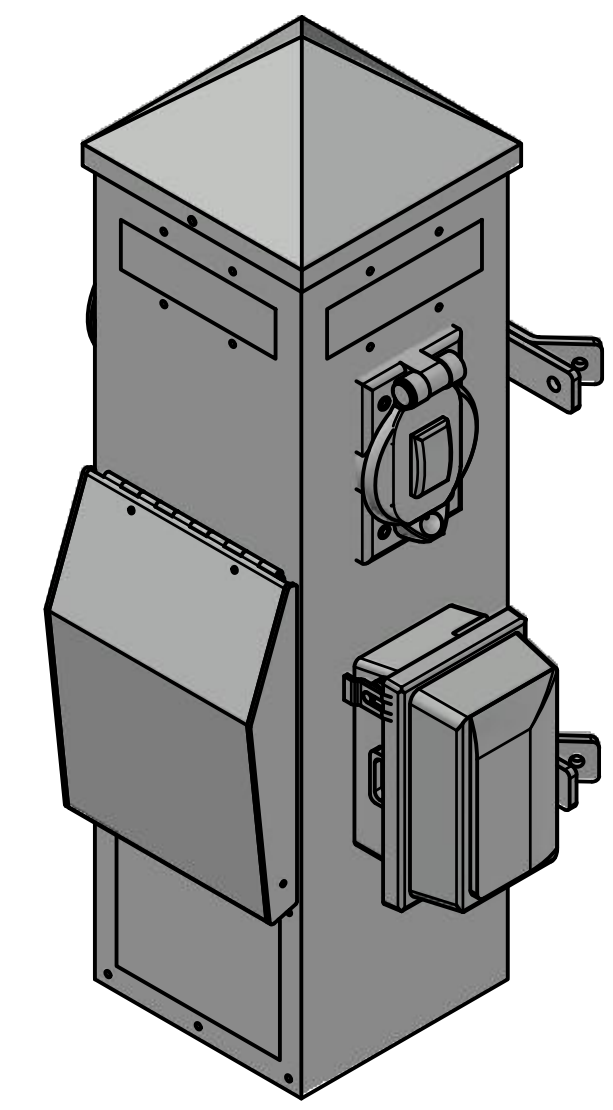

NOTES:
 1. ALL DIMENSIONS ARE IN INCHES
 2. MATERIAL THICKNESS IS 0.125 INCHES

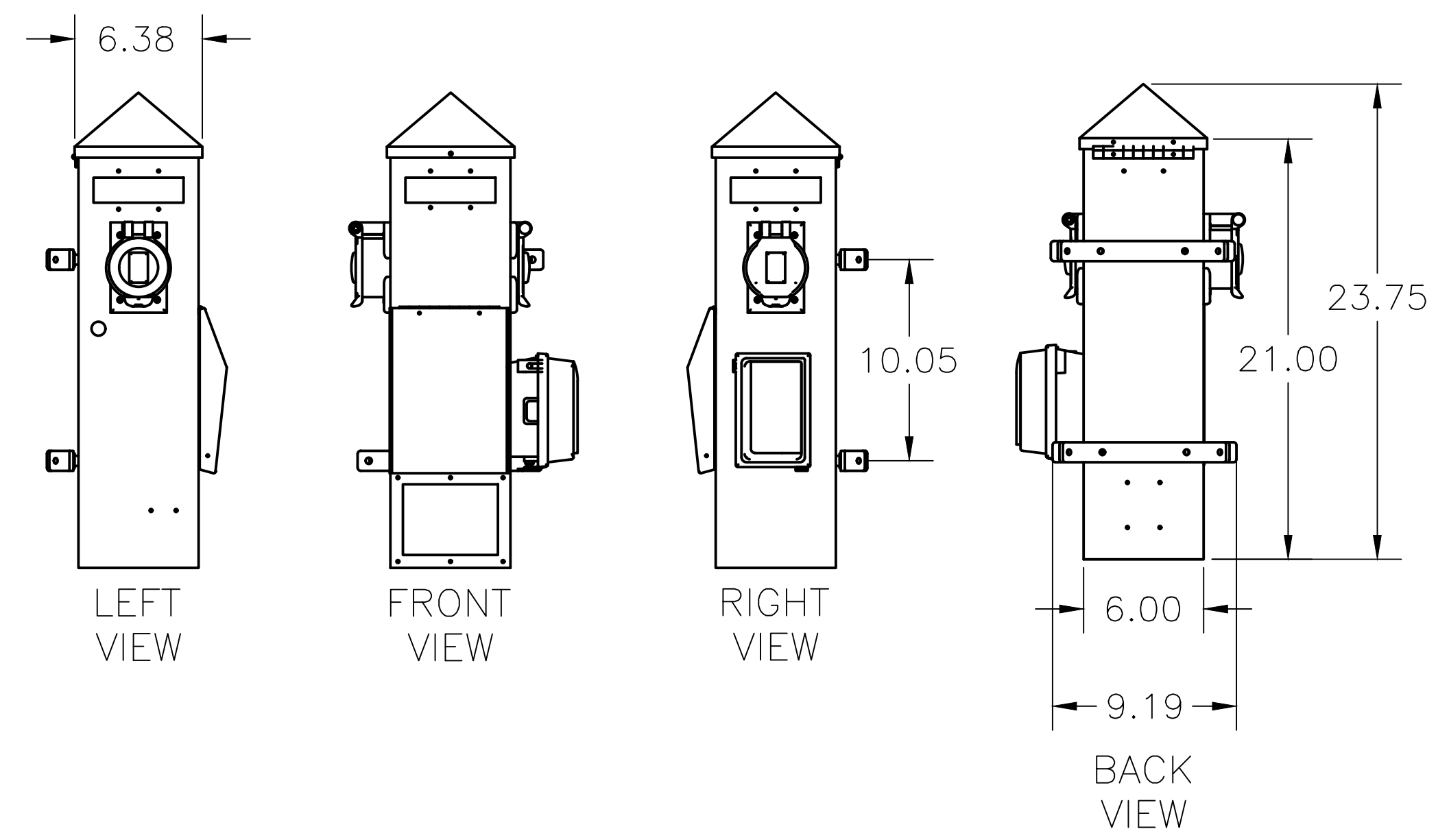
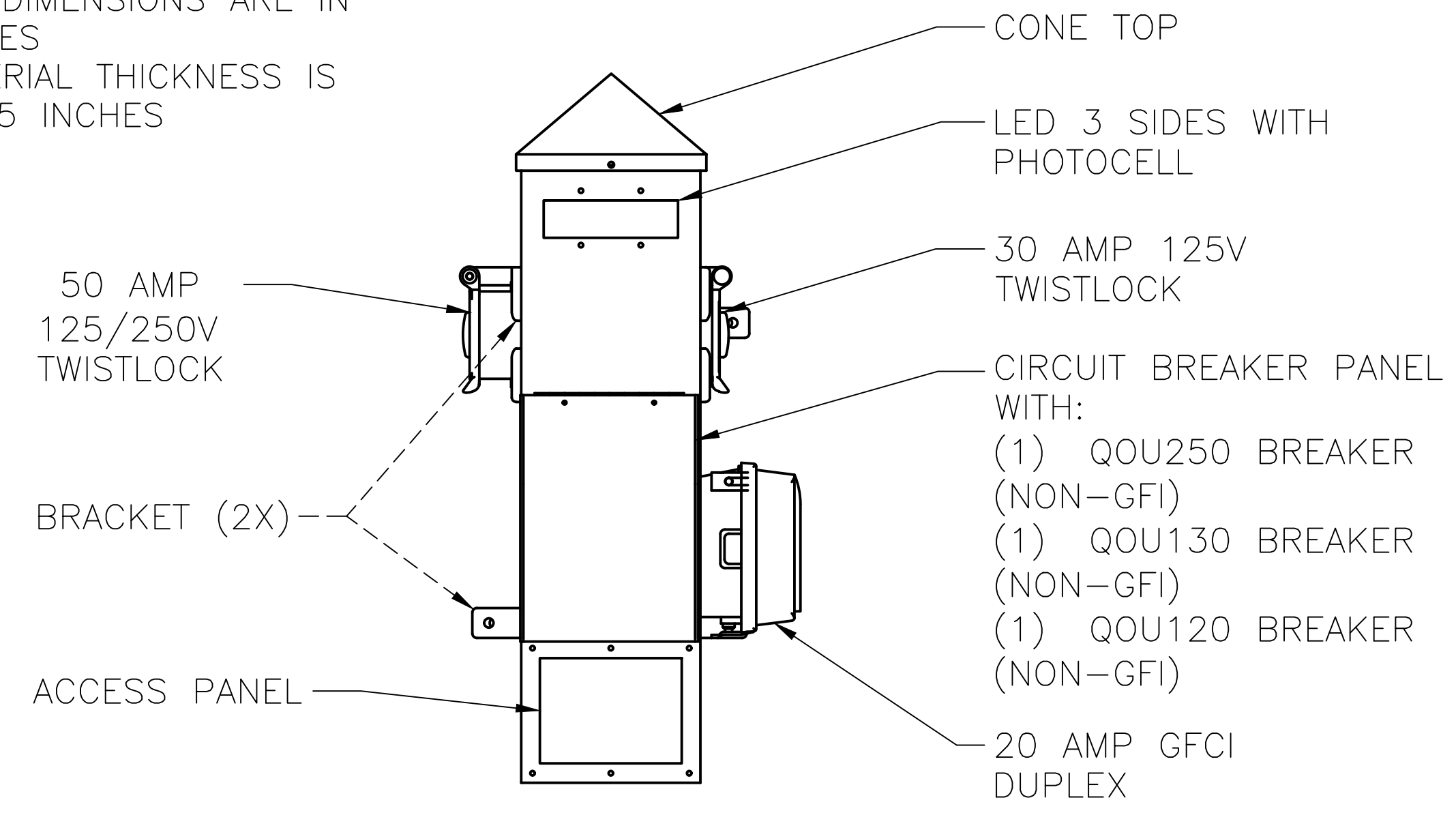

NOTES:
 PEDESTAL FABRICATED FROM 100% ALUMINUM CASING
 6" X 6" X 21" X 1/8"
 POWDER COATED WHITE TO MARINE SPECIFICATIONS

FILE NAME SP-21-ASSEMBLY_WebVer.dwg					
CONTRACT NO NA		SPC-21-3T-XXX-XXX			
DRAWN 11/8/2024					
CHECK					
APPR.					
ISSUED		SIZE	FSCM NO	DWG NO	REV
		-		SPC-21-3T-XXX-XXX	A
SCALE 1:0.987		WEIGHT		SHEET 1 OF 1	

Client shall review and accept any engineering drawing prepared by International Dock Products, Inc. prior to commencing manufacturing of product.

ACCEPTED

CLIENT NAME: _____ CLIENT SIGNATURE: _____ DATE APPROVED: _____

08.11.2024 Roman